

Warning

- Only qualified service personnel should install and service this product to avoid injury.
- Observe all ESD procedures during installation to avoid damaging the equipment.

1 Preparing tools

Unpack the equipment and make sure the following tools are available and delivered contents are correct before you begin the installation procedure.

- 1-1. User-provided tools
- Anti-static wrist wrap

1-2. Packing List

Item	Description	Qty
01	Nuvis-534RT system	1
02	Drivers & utilities disc	1
03	3-pin pluggable terminal block	2
04	DIN-rail mount clip	1
05	Screw package	1
06	TB-10	1
07	SCIS-68 male to SCSI-68 male 100cm cable	1

2 Nuvis-534RT Front Panel

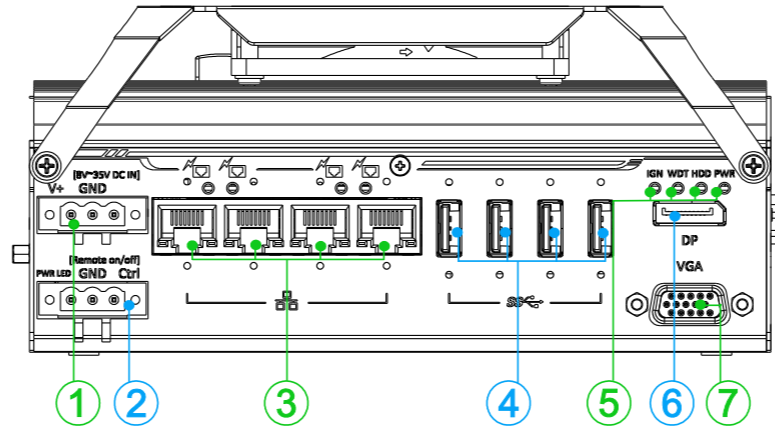

No.	Item	Description
1	3-pin DC terminal block	Compatible with DC power input from 8~35V.
2	3-pin Remote on/off control	Allows for external switch extension when the system is placed inside a cabinet.
3	Gigabit PoE+ ports	Gigabit Power over Ethernet (PoE) port can provide both data and electric power to devices.
4	USB 3.1 Gen1 port	USB 3.1 Gen1 port, up to 5 Gbit/s data transfer bandwidth.
5	System status LED	Four system LEDs, IGN (Reserved), WDT (Watchdog Timer), HDD (Hard Disk Drive) and PWR (Power).
6	DisplayPort output	The DisplayPort is a high-resolution graphics output supporting up to 4096 x 2160 @ 30Hz.
7	VGA port output	VGA output supports resolution up to 1920x1200@60Hz

3 3-pin DC Terminal Block

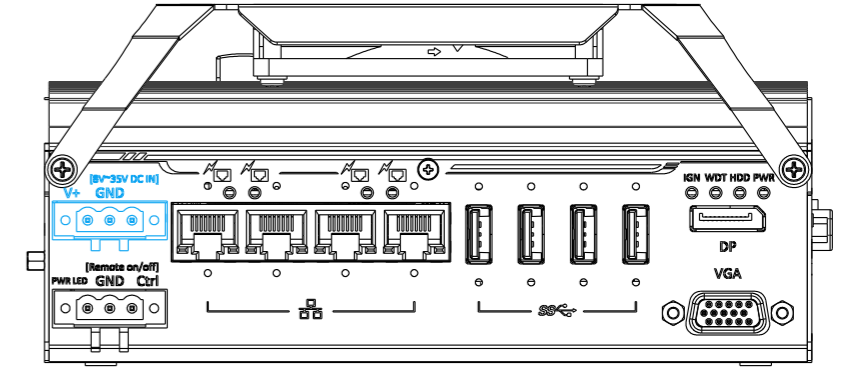

The system accepts a wide range of DC power input from 8 to 35V via a 3-pin pluggable terminal block, which is fit for field usage where DC power is usually provided. The screw clamping mechanism on the terminal block offers connection reliability when wiring DC power.

Warning

Please make sure the voltage of DC power is correct before you connect it to the system. Supplying a voltage over 35V will damage the system.

4 3-pin Remote On/ Off

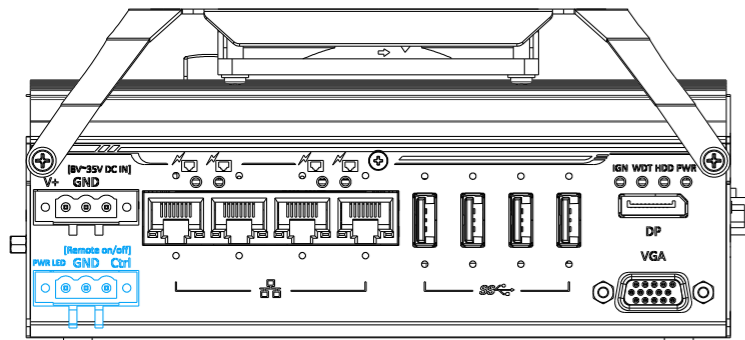

The "Remote On/ Off" 3-pin connection allows for external switch extension. It is useful when the system is placed in a cabinet or a not easily accessed location. You may connect an external remotewith an external status LED indicator(15mA) by connecting toPWR LED and GND.

5 IEEE 802.3at Power over Ethernet Port

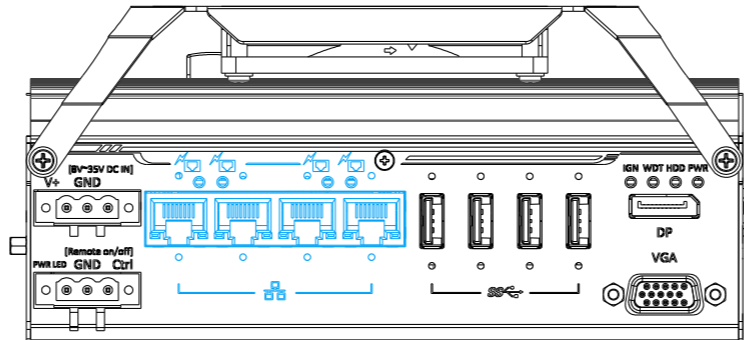

The Gigabit Power over Ethernet(PoE) port supply power and data on a standard CAT-5/CAT-6 Ethernet cable. Acting as a PSE (Power Sourcing Equipment), compliant with IEEE 802.3at,each port delivers up to 25W to a Powered Device(PD). PoE automatically detects and determine if the connected device is PoE PD or not before supplying power, making it compatible with standard Ethernet devices as well.

Active/Link LED (Right)

LED Color	Status	Description
Green	Off	Ethernet port is disconnected
	On	Ethernet port is connected and no data transmission
	Flashing	Ethernet port is connected and data is transmitting/receiving

Speed LED (Left)

LED Color	Status	Description
Green or Orange	Off	10 Mbps
	Green	100 Mbps
	Orange	1000 Mbps

6 USB3.1 Gen1

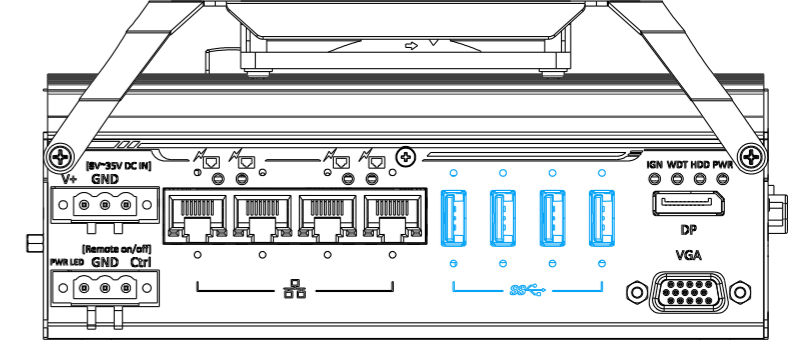

The system offers four USB 3.1 Gen1(SuperSpeed USB) ports on its front panel. They are backward compatible with USB 2.0, USB 1.1 and USB 1.0 devices. Legacy USB support is also provided so you can use USB keyboard/mouse in DOS environment while USB3.1 Gen1 driver is supported natively in Windows10.

7 System Status LED

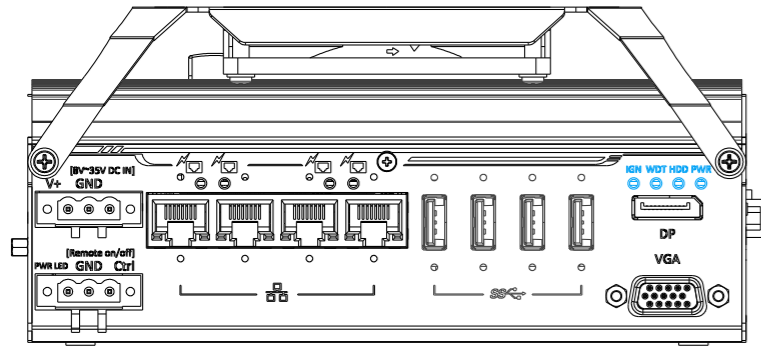

There are four LEDs on the front panel: IGN (reserved), WDT, HDD and PWR. The descriptions of these four LEDs are listed in the following table.

Indicator	Color	Description
IGN	Reserved	Reserved
WDT	Yellow	Watchdog timer indicator, flashing when watchdog timer has started
HDD	Red	Hard drive indicator, flashing when SATA HDD is active
PWR	Green	Power indicator, lid when system is on

8 DisplayPort

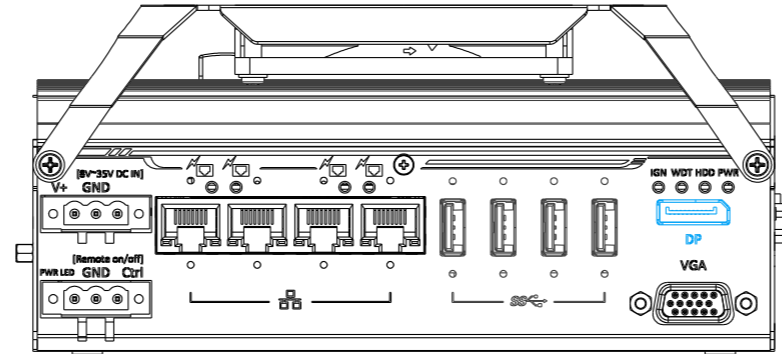

The system has a DisplayPort (DP) output which is a digital display interface that mainly connect video source and carry audio to a display device. When connecting a DP, it can deliver up to 4K UHD (4096 x 2160@ 30Hz) in resolution. The system is designed to support passive DP adapter/ cable. You can connect to other display devices using DP-to-HDMI cable or DP-to-DVI cable.



DP-to-HDMI

DP-to-DVI

The system supports dual independent display outputs by connecting display devices to VGA and DisplayPort connection. To support dual display outputs and achieve best DisplayPort output resolution in Windows, you need to install corresponding graphics drivers.

9 VGA Port

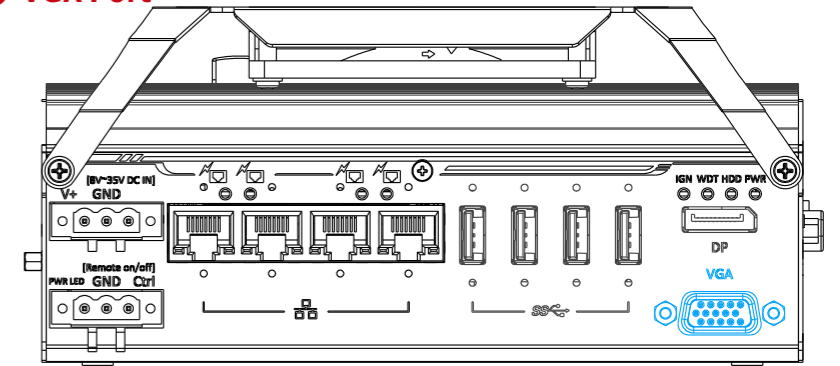

VGA connector is the most common video display connection. The VGA output supports up to 1920x1200@60Hz resolution. The system supports dual independent display outputs by connecting display devices to VGA and DisplayPort connection. To support dual display outputs and achieve best VGA output resolution in Windows, you need to install corresponding graphics drivers.

Note

Please make sure your VGA cable includes SDA and SCL (DDC clock and data) signals for correct communication with monitor to get resolution/timing information. A cable without SDA/ SCL can cause blank screen on your VGA monitor due to incorrect resolution/timing output.

10 Nuvis-534RT COM Port Panel

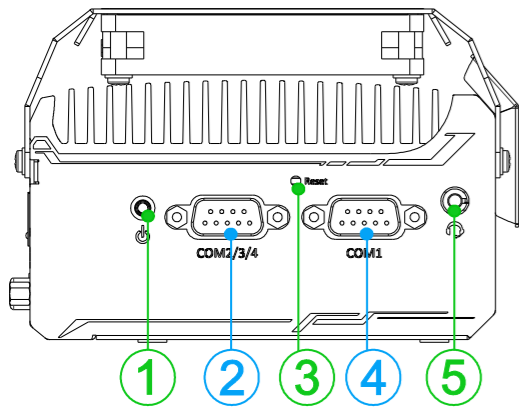

No.	Item	Description
1	Power button	Use this button to turn on or shutdown the system.
2	COM port 2/ 3/ 4	Can be configured as: COM2: single RS-422/ 485 port COM2/ COM3/ COM4: three 3-wire RS-232 ports
3	Reset button	Use this button to manually reset the system.
4	COM port 1	Software programmable RS-232/ 422/ 485 port.
5	3.5mm speaker-out/ microphone-in jack	3.5mm jack for speaker-out or microphone-input.

11 Power Button

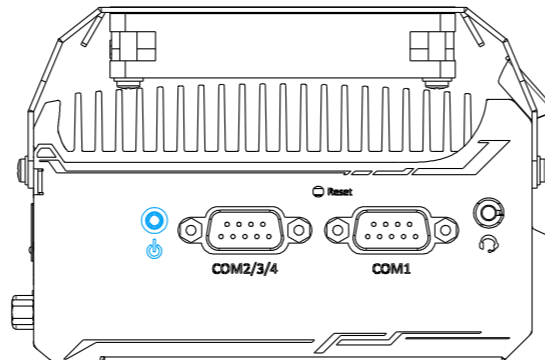

The power button is a non-latched switch for ATX mode on/off operation. Press to turn on the system, PWR LED should light up and to turn off, you can either issue a shutdown command in the OS, or just press the power button. In case of system halts, you can press and hold the power button for 5 seconds to force-shutdown the system. Please note that there is a 5 seconds interval between two on/off operations (i.e. once turning off the system, you will need to wait for 5 seconds to initiate another power-on operation).

12 COM1 Port

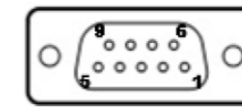
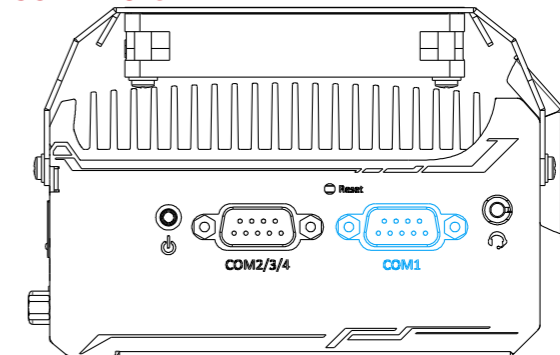

Implemented using industrial-grade ITE8786 Super IO chip (-40 to 85°C) and provide up to 921600 bps baud rate, COM1 is a software-configurable RS-232/422/485 port via 9-pin D-Sub male connector. The operation mode, slew rate and termination of COM1 can be set in BIOS setup utility. The following table describes the pin definition of COM ports.

Pin#	COM1		
	RS-232 Mode	RS-422 Mode	RS-485 Mode (Two-wire 485)
1	DCD		
2	RX	422 TXD+	485 TXD+/RXD+
3	TX	422 RXD+	
4	DTR	422 RXD-	
5	GND	GND	GND
6	DSR		
7	RTS		
8	CTS	422 TXD-	485 TXD-/RXD-
9	RI		

13 COM2/3/4 Port

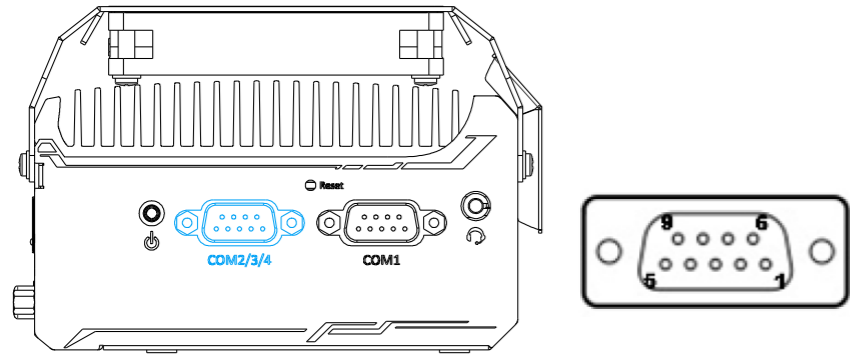

Implemented using industrial-grade ITE8786 Super IO chip (-40 to 85°C) and provide up to 921600 bps baud rate, the D-Sub male connector (COM2/ 3/ 4) can be configured in the BIOS as single RS-422/ 485 port (COM2) or three 3-wire RS-232 ports (COM2/COM3/COM4).

3-port RS-232 COM2/ 3/ 4			
Pin#	COM2	COM3	COM4
1			
2	RX		
3	TX		
4		TX	
5	GND	GND	GND
6		RX	
7			TX
8			RX
9			

Single port RS-422/ 485		
Pin#	RS-422	RS-485
1		
2	TxD+	TxD+/ RxD+
3	RxD+	
4	RxD-	
5	GND	GND
6		
7		
8	TxD-	TxD-/ RxD-
9		

14 Reset Button

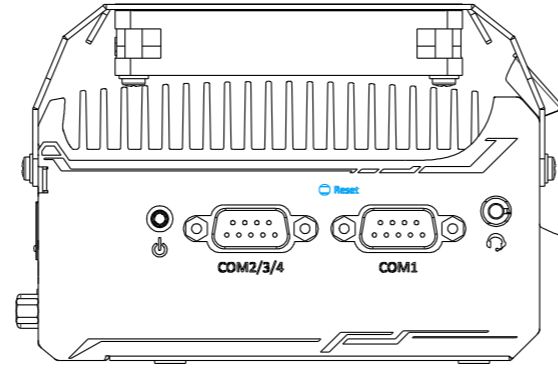

The reset button is used to manually reset the system in case of system halt or malfunction. To avoid unexpected reset, the button is purposely placed behind the panel. To reset, please use a pin-like object (eg. tip of a pen) to access the button.

15 4-pole 3.5mm Microphone-in/ Speaker-out Jack

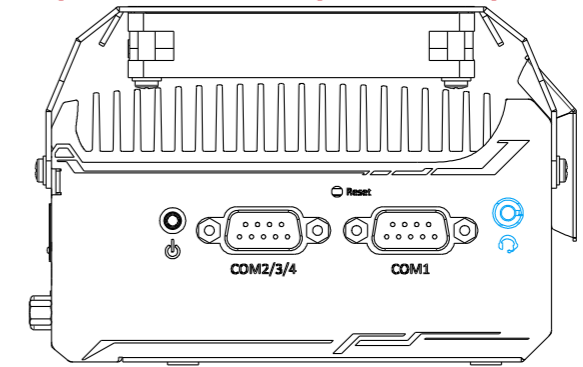

There is a female 4-pole audio jack for headphone (speaker) output and microphone input. To utilize the audio function in Windows, you need to install corresponding drivers.

16 Real-time Vision IO Panel

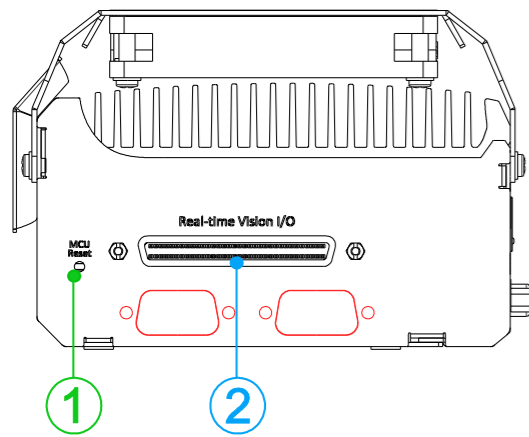

The real-time vision I/O panel has an MCU reset button, a real-time vision I/O connector and reserved DB9 openings.

No.	Item	Description
1	MCU Reset Button	Use a pin-like object to press the MCU button to reset the MCU without resetting the whole system.
2	Real-time Vision I/O	Vision specific trigger/ strobe control input/ output for vision/ imagery purposes.
		Reserved DB9 port opening

17 MCU Reset Button

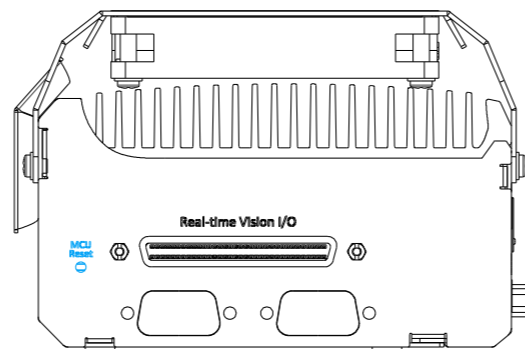

You may use the MCU reset button to manually reset the MCU without resetting the whole system. To avoid unexpected resets, the button is purposely placed behind the panel. To reset, please use a pin-like object (eg. tip of a pen) to access the reset button.

18 Real-time Vision IO Connector

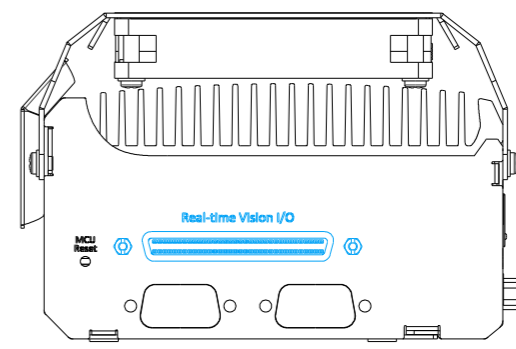

Real-time vision I/O is managed by Neosys' patented MCU-based architecture and DTIO/ NuMCU firmware for microsecond-scale realtime I/O control. It also supports various machine vision peripherals such as CC/ CV lighting controller, quadrature encoder input, PWM output, isolated DI/ DO, 12V camera trigger output etc.

17 Vision Specific I/O: TB-10 Pin Connector



Signal		ISO5V				ISOGND	PHA	PHB	ISOGND	DI4L	DI4H	DI5L	DI5H	DI6L	DI6H	DI7L	DI7H
Pin	52	53	54	55	56	57	58	59	60	61	62	63	64	65	66	67	68
Pin	18	19	20	21	22	23	24	25	26	27	28	29	30	31	32	33	34
Signal		DOGND				ISOGND	IDX			DI0L	DI0H	DI1L	DI1H	DI2L	DI2H	DI3L	DI3H

Signal	LED0+	LED0-	LED1+	LED1-	DOGND	DO0	DOGND	DO1	DOGND	DO2	DOGND	DO3	VDD	DOGND	TRIG0	DOGND	TRIG1
Pin	1	2	3	4	5	6	7	8	9	10	11	12	13	14	15	16	17
Pin	35	36	37	38	39	40	41	42	43	44	45	46	47	48	49	50	51
Signal	LED2+	LED2-	LED3+	LED3-	DOGND	DO4	DOGND	DO5	DOGND	DO6	DOGND	DO7	ISO5V	DOGND	TRIG2	DOGND	TRIG3

Signal	Function Description
LED0+/ LED0- LED1+/ LED1- LED2+/ LED2- LED3+/ LED3-	<p>LED driving output</p> <p>LED0~LED3 are used to directly drive LED lights in the vision system. Each channel can be configured to output 24V constant voltage or user-programmable, up to 2A constant current to drive either CV or CC LED light using DTIO or NuMCU library. The LED driving output also supports digital dimming control by adjusting duty cycle from 0 to 100%. When connecting LED lights, wire LED+ to positive polarity (anode) and LED- to negative polarity (cathode).</p> <p>Note</p> <p>Total power budget for four LED output channels is limited to 80W. Users shall cautiously program the LED outputs and make sure all connected LED lights consume less than 80W at the same time.</p>
DO0/ DOGND DO1/ DOGND DO2/ DOGND DO3/ DOGND	<p>Isolated digital output (high-current)</p> <p>DO0~DO3 are open-drained DO channels designed to control external actuator devices, such as relay, valve and motor. Each channel can carry up to 24VDC, 500mA rated current.</p>
DO4 (PWM0)/ DOGND DO5 (PWM1)/ DOGND DO6 (PWM2)/ DOGND DO7 (PWM3)/ DOGND	<p>Isolated digital output (high-speed) or PWM output</p> <p>DO4~DO7 are open-drained DO channels implemented using Darlington transistors. It offers <1us propagation delay and is ideal for high-speed signals such as triggers. Users can also configure these channels as PWM function in DTIO or NuMCU to generate PWM signals (external voltage source required). Each channel can carry up to 24VDC, 50mA rated current.</p>
TRIG0/ DOGND TRIG1/ DOGND TRIG2/ DOGND TRIG3/ DOGND	<p>12V camera trigger output</p> <p>TRIG0~TRIG3 are camera trigger output channels that offer isolated 12V output (push-pull DO). Users can simply wire TRIGx and DOGND to camera's trigger-in/GND directly without the need of external voltage source. Each channel can offer maximal 50mA current output with <1us propagation delay.</p>

DI0H/DI0L DI1H/DI1L DI2H/DI2L DI3H/DI3L DI4H/DI4L	DI5H/DI5L DI6H/DI6L DI7H/DI7L	<p>Isolated digital input</p> <p>DI0~DI7 are opto-isolated channels for digital input. Each channel has separated ground pin so users shall wire DI signal to DIxH and DIxL. The isolated DI is logic low when input voltage is 0~1.5V and logic high when input voltage is 5~24V.</p>																																
PHA PHB IDX ISOGND		<p>Quadrature encoder input</p> <p>PHA, PHB and IDX are pins for quadrature encoder input. It support either single-ended encoder or differential encoder by jumper selection. Please refer to the following table for correctly wire your quadrature encoder.</p> <table border="1"> <thead> <tr> <th colspan="2">Single-ended encoder</th> <th colspan="2">Differential encoder</th> </tr> <tr> <th>Pin#</th> <th>Wire to encoder's</th> <th>Pin#</th> <th>Wire to encoder's</th> </tr> </thead> <tbody> <tr> <td>57</td> <td>GND</td> <td>57</td> <td>A-</td> </tr> <tr> <td>58</td> <td>A</td> <td>58</td> <td>A+</td> </tr> <tr> <td>59</td> <td>B</td> <td>59</td> <td>B+</td> </tr> <tr> <td>60</td> <td>GND</td> <td>60</td> <td>B-</td> </tr> <tr> <td>23</td> <td>GND</td> <td>23</td> <td>Z-</td> </tr> <tr> <td>24</td> <td>Z</td> <td>24</td> <td>Z+</td> </tr> </tbody> </table>	Single-ended encoder		Differential encoder		Pin#	Wire to encoder's	Pin#	Wire to encoder's	57	GND	57	A-	58	A	58	A+	59	B	59	B+	60	GND	60	B-	23	GND	23	Z-	24	Z	24	Z+
Single-ended encoder		Differential encoder																																
Pin#	Wire to encoder's	Pin#	Wire to encoder's																															
57	GND	57	A-																															
58	A	58	A+																															
59	B	59	B+																															
60	GND	60	B-																															
23	GND	23	Z-																															
24	Z	24	Z+																															